

auto electrical parts

Technical Information Sheet

Part No. 0-605-51

Battery isolator, double pole with removable key and splashproof cover. Rated 250 amps at 24 volts and 2500 amps for 5 seconds. Connects or disconnects both poles simultaneously. Requires 24mm hole, M10 studs. Housing protected to IP66.

Additional Information

A replacement key is available, part 0-605-55



TERMS	0	1
1-2		■
3-4		■

Technical Drawing (not to scale)

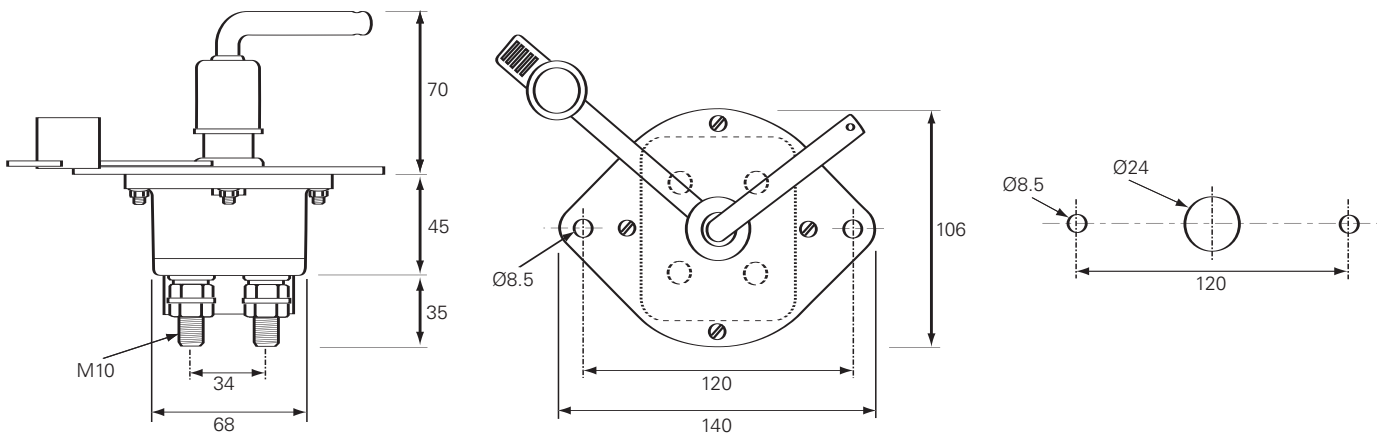

Specification

Type	Double pole battery isolation switch
Voltage	48 volt dc maximum
Current @24vdc	250 amp continuous 2500 amp (5 secs)
Contacts	Copper
Bolts	M10 copper
Tightening torque	15Nm
Temperature	-40° to 85°C
Weight	1Kg
Dimensions	l 140 x w 106 x h 150mm
Protection	IP66

The information contained in this document is correct to the best of our knowledge at the time of printing. However, specifications may change at any time without notice.

Gordon Equipments Limited

Durite Works
Valley Road
Dovercourt
Essex CO12 4RX
England

Tel: +44 (0)1255 555200
Fax: +44 (0)1255 555222
E-mail: sales@durite.co.uk
Web: www.durite.co.uk



Registered in England at address shown No. 373113
The words 'Gordon', 'Durite', 'Nolten' and 'Acfil' are registered trade marks